



VIP LIFT

TECHNOLOGIE

INSTALLATION MAINTENANCE ENTRETIEN ET REPARATION
DES ASCENSEURS ET AUTRES APPAREILS SIMILAIRES





VIP LIFT

TECHNOLOGIE

VIP LIFT Technologie est spécialisé dans l'installation, réparation maintenance et entretien des ascenseurs et d'autres appareils similaires.

Nos services ont par conséquent pu acquérir l'expérience et la compétence pour étudier, planifier, estimer le budget nécessaire à de telles opérations et conduire ou accompagner un projet de la phase d'étude jusqu'à son terme.

A cet effet, nous nous tenons à votre disposition pour vous accompagner et mener à bien tous vos projets que vous choisiriez de nous confier.

Dans l'espérance de retenir votre attention lors de votre consultation, nous vous prions de croire, chère madame, cher monsieur, en l'assurance de nos sentiments les plus dévoués.



VIP LIFT
TECHNOLOGIE

PRODUIT :

ASCENSEUR
ELECTRIQUE

- * VSPACE
- * MEDIEM
- * VM/VMBE
- * EESY



Btiments existants



Btiments publics



Hotels



Résidentiel

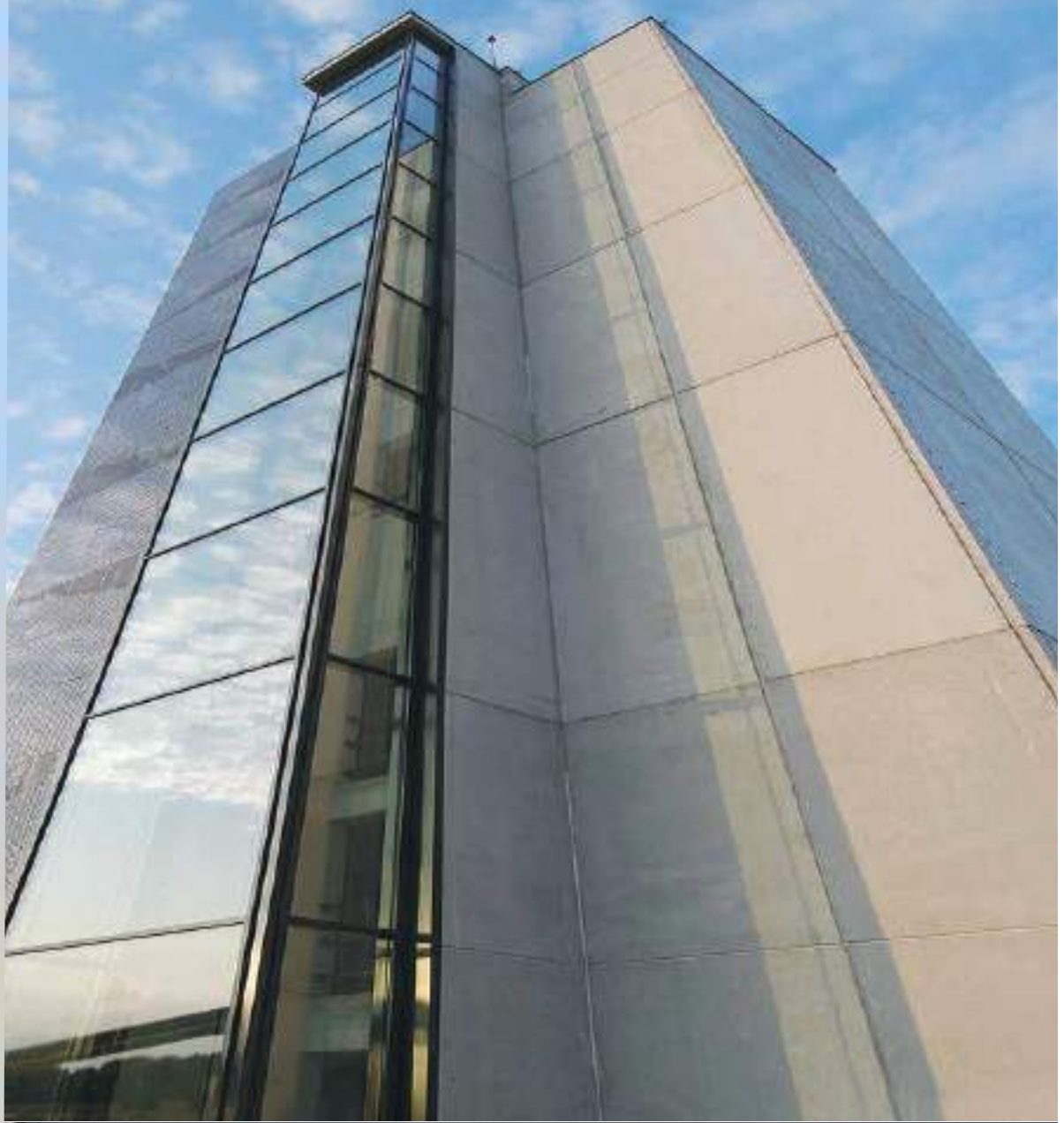

ESCALATOR



Outdoor Escalator type
Modèle d'escalier mécanique extérieur

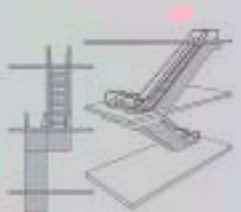

Caractéristiques techniques :

- Vitesse nominale 1 m/s 3VF jusqu'à 2,5 m/s
- Charge nominale jusqu'à 3.000 kg
- Câble 6,5 / 8 mm. (> 1.250 kg)
- Suspension 2:1

(kg)	CU VETTE MINIMUM EN 81-21		DERNIER ÉTAGE MINIMUM EN 81-21	
	Cuvette min. (mm)	Dernier étage nécessaire (mm)	Cuvette nécessaire (mm)	Dernier étage min. (mm)
180-450	320	3320	640	2550
630	320	3320	695	2650
1000	670	3200	700	3200
1250	670	3200	700	3200
1600	400	3300	700	3300
2000	1020	3700	1020	3700
2500	1020	3700	1020	3700
3000	1020	3700	1020	3700

(kg)	LG	PG	LC	PC	PL
180	1310	960	750	750	700
225	1310	1100	750	870	700
320	1400	1300	900	1000	700
450	1500	1460	1020	1210	800
630	1600	1660	1120	1410	800
800	1930	1750	1300	1500	900
1000	1600	2350	1100	2100	900
1125	2000	2350	1250	2100	1000
1250	2050	2350	1300	2100	1000
1600	2250	2500	1500	2250	1200
2000	2150	3050	1500	2700	1300
2500	2650	3050	1800	2700	1600
3000	2750	3050	1900	2700	1600

Largeur Gaine PC Profondeur Cabine
 Profondeur Gaine PL Passage Libre
 Largeur Cabine

LG
 PG
 LC

• Symbio

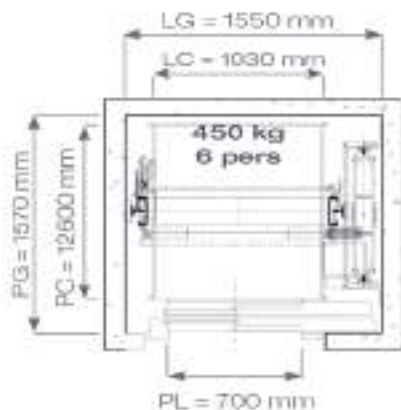

• Optimus

Utilisation de la gaine maximale

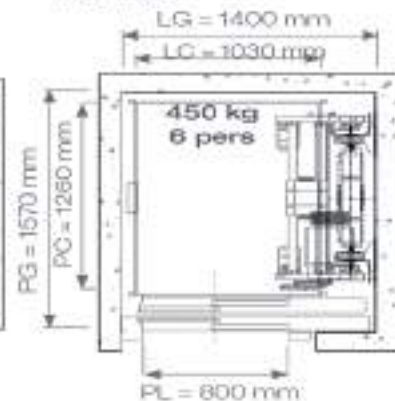

VIP LIFT
TECHNOLOGIE

PRODUIT :

- ASCENSEURS DE MAISON
- MONTE-CHARGES
- ELÉVATEURS PMR

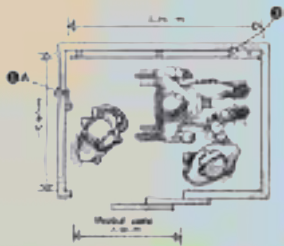

PRODUIT :

- MONTE-CHARGE ACCOMPAGNÉ
- ASCENSEURS SECTEUR COMMERCIAL
- MONTE-VOITURE



ENGAGEMENT



Garanti de votre sécurité, VIP Lift technologie a mis en place des programmes de maintenance préventive et corrective vous assurant ainsi une sérénité dans vos déplacements.

MAINTENANCE PREVENTIVE, LA TRANQUILLITÉ à LONG TERME

Le programme de maintenance préventive proposé par VIP Lift technologie intègre des visites d'entretien dont la périodicité varie selon le type d'équipement et la réglementation en vigueur.

Durant ces visites nos techniciens réalisent le contrôle et l'entretien des différents organes de vos équipements afin de garantir un fonctionnement optimal à long terme.

FRÉQUENCE DES VISITES DE MAINTENANCE

Ascenseur de personnes	Élévateur pour personne à mobilité réduite	Monte charge Non-accompagné	Escalier mécanique & trottoir roulant	Porte & automatisme
Toutes les 6 Semaines	Tous les 6 Mois	Tous les 1 Mois	Tous les 1 Mois	Tous les 6 Mois

MAINTENANCE CORRECTIVE, RÉACTIVITÉ ET EFFICACITÉ ASSURÉES

Nos techniciens interviennent ponctuellement sur vos équipements afin de réaliser une maintenance corrective. Les horaires et délais d'intervention sont choisis avec vous en fonction de vos besoins

DELAIS D'INTERVENTION

DIAGNOSTIC		INTERVENTION TECHNIQUE	
<input type="checkbox"/> 4 h	Inclus	<input type="checkbox"/> 24 h	Inclus
<input type="checkbox"/> 2 h	En option	<input type="checkbox"/> 12 h	En option

PRODUIT :

- ASCENSEUR ELECTRIQUE
- ASCENSEUR HYDRAULIQUE
- HOMELIFT
- MONTE CHARGES
- MONTE MALADES
- MONTE VOITURE
- MONTE PLATS



Qualite



Innovation

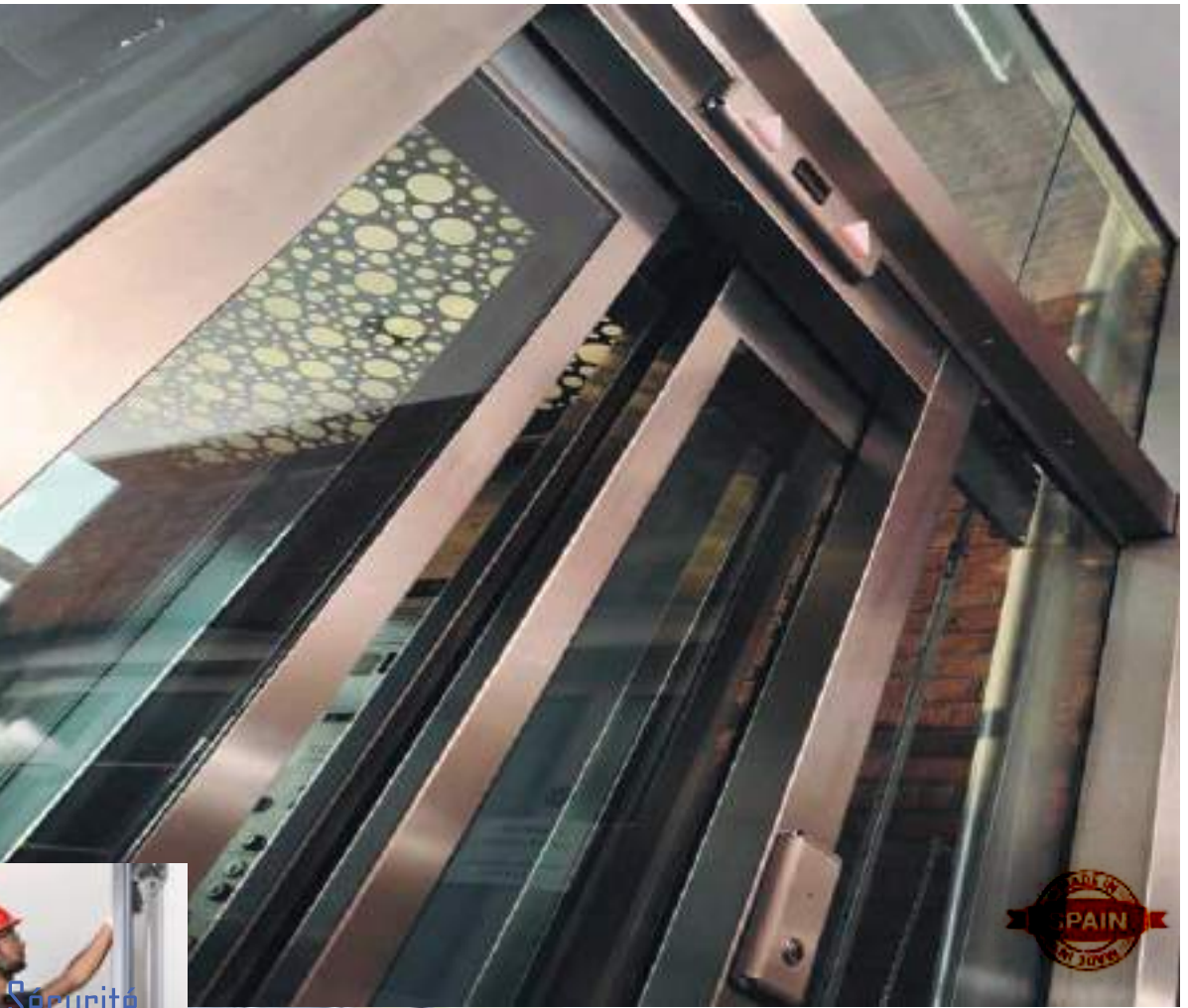
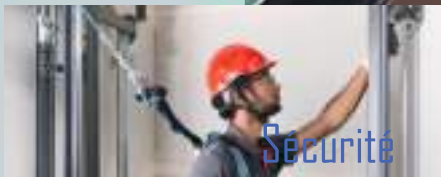

PRODUIT :

- ASCENSEUR ELECTRIQUE
- ASCENSEUR HYDRAULIQUE
- HOMELIFT



CABINES D'ASCENSEURS



E100



E200



E210



E250



E280



E300



E400



E500



E510



E710



CABINES D'ASCENSEURS

M01-L01



Parois



Mé laminé Lino
Habana

Sols

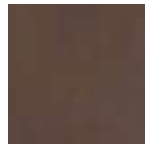

Pierre artificielle
Gedatsu

M02-L02



Parois



Formica
Pin Cervino

Sols



Linoleum
Gris foncé

M03 - L03



Parois

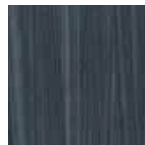

Formica Burnt
Strand

Sols



Caoutchouc
antidérapant
Noir

M04 - L04



Parois



Formica Cerisier

Sols



Caoutchouc
antidérapant Noir

S01



Parois



Skinplate simile
inox.

Sols



Caoutchouc pastilles
rondes Noir

I01



Parois

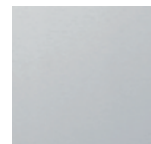

Acier inox. satiné

Sols



Linoleum Noir





VIP LIFT

TECHNOLOGIE

CENTRE D'AFFAIRE BAB EZZOUAR, CITE BOUSHAKI N°185 ALGER, ALGERIE

TEL : 00213 553 089 683 00213 559 958 042

EMAIL : CONTACT@VIPLIFT-DZ.COM

WEB : WWW.VIPLIFT-DZ.COM